

INTERACE CONTROL DOCUMENT

- WEIGHT: 13.3 oz [378 g] (WITHOUT BATTERY)
- TO PREVENT DAMAGE TO LIGHT AND SURFACE DUE TO EXCESSIVE HEAT BUILD UP, DO NOT OPERATE LIGHT FACE DOWN ON ANY SURFACE.

# CONSTELLATION™-160B mini

160 WATT INTELLIGENT LED LUMINAIRE - 82 FWHM BEAM ANGLE  
WITH BATTERY CAPABILITY

REVISIONS					
ZONE	REV.	ECO #	DESCRIPTION	DATE	APPROVED
	A	-	INITIAL RELEASE.	04/16/2018	B. MOAK

AIR EXHAUST SIDE  
DO NOT OBSTRUCT

AIR INTAKE SIDE  
DO NOT OBSTRUCT

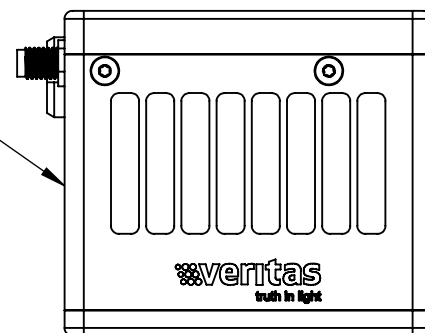

LOCATIONS NOT FOR MOUNTING.  
FOR BATTERY ATTACHMENT ONLY

SMA: SYNC IN

LEMO 8-PIN A-KEY:  
POWER 24V DC

LED INDICATOR:  
GREEN: CONTINUOUS  
BLUE: PULSE CONTROL  
RED: POWER UP/FAULT

POWER BUTTON:  
TAP TO POWER ON,  
TAP TO SWITCH MODES,  
HOLD FOUR SECONDS AND  
RELEASE FOR POWER DOWN

SMA: SYNC OUT

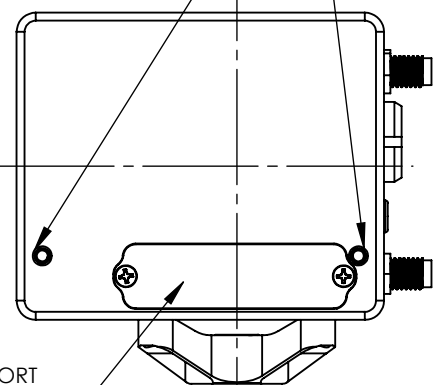

BATTERY PORT  
COVER PLATE

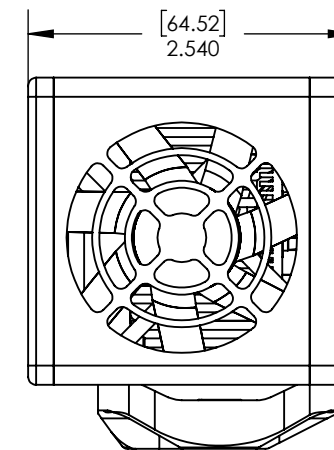
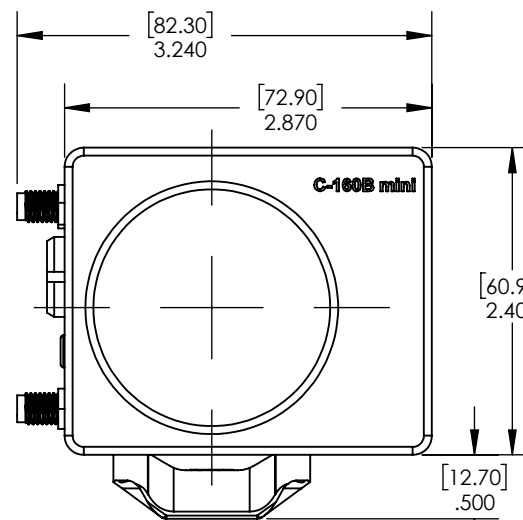

TRIPOD ANTI-ROTATION  
PIN SLOT  $\nabla$  0.250 [5.38]

4X #4-40 MOUNTING HOLES  
 $\nabla$  0.200 [5.08]

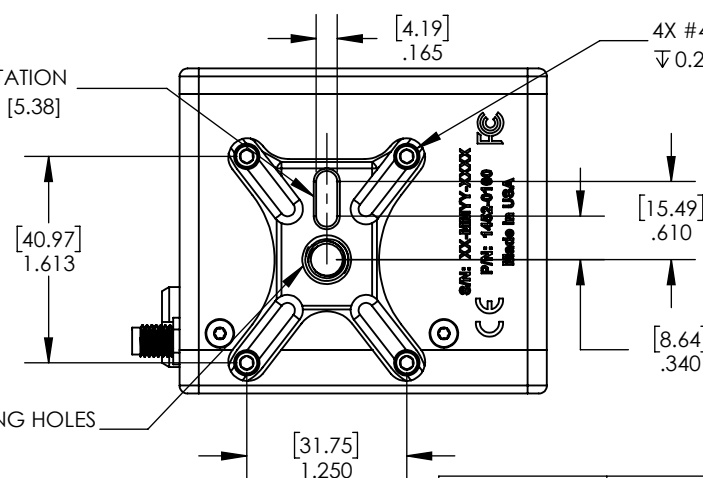

1/4-20 MOUNTING HOLES  
 $\nabla$  0.375 [9.53]

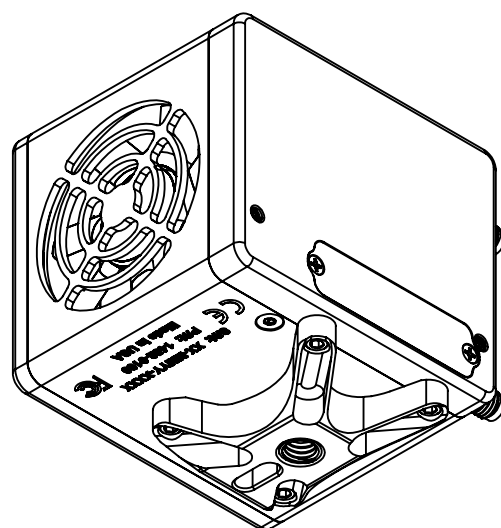
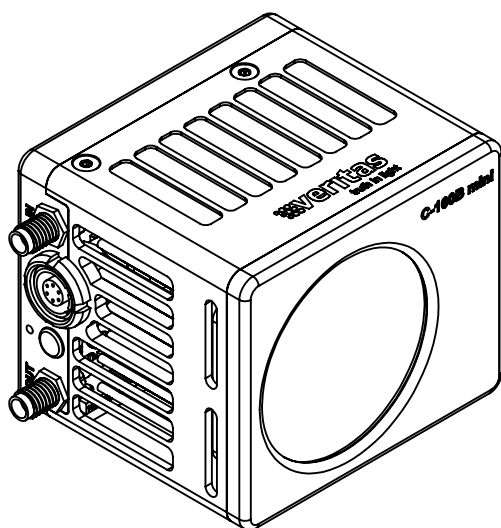

<p>PROPRIETARY AND CONFIDENTIAL</p> <p>THE INFORMATION CONTAINED IN THIS DRAWING IS THE SOLE PROPERTY OF INTEGRATED DESIGN TOOLS, INC. ANY REPRODUCTION IN PART OR AS A WHOLE WITHOUT THE WRITTEN PERMISSION OF INTEGRATED DESIGN TOOLS, INC. IS PROHIBITED.</p>	<p>PROJECT NAME: C-160B mini</p>	<p>INTEGRATED DESIGN TOOLS, INC</p> <p>1 WEST MOUNTAIN STREET SUITE 3 PASADENA, CA 91103</p>
	<p>UNLESS OTHERWISE SPECIFIED: DIMENSIONS ARE IN INCHES TOLERANCES ON: FRACTIONAL DECIMAL ANGULAR <math>\pm 1/16</math> .X <math>\pm .03</math> <math>\pm 1^\circ</math> .XX <math>\pm .01</math> .XXX <math>\pm .005</math></p>	<p>DATE: 4/23/2018</p> <p>DATE: 4/23/2018</p> <p>DATE: 4/23/2018</p>
<p>THIRD ANGLE PROJECTION</p>	<p>DRAWN: B. MOAK</p> <p>CHECKED: D. ATOL</p> <p>MECH. ENGINEER: B. MOAK</p> <p>ELECTRICAL ENGINEER:</p> <p>OPERATION MANAGER:</p> <p>PROGRAM MANAGER:</p>	<p>SIZE: <b>B</b></p> <p>DWG. NO. 1452-0100</p> <p>SCALE: 2:3</p> <p>DATE: 4/23/2018</p> <p>REV <b>A</b></p> <p>SHEET 1 OF 2</p>

DO NOT SCALE DRAWING

8 7 6 5 4 3 2 1

# BATTERY ATTACHMENT

A  
B  
C  
D  
E

A  
B  
C  
D  
E

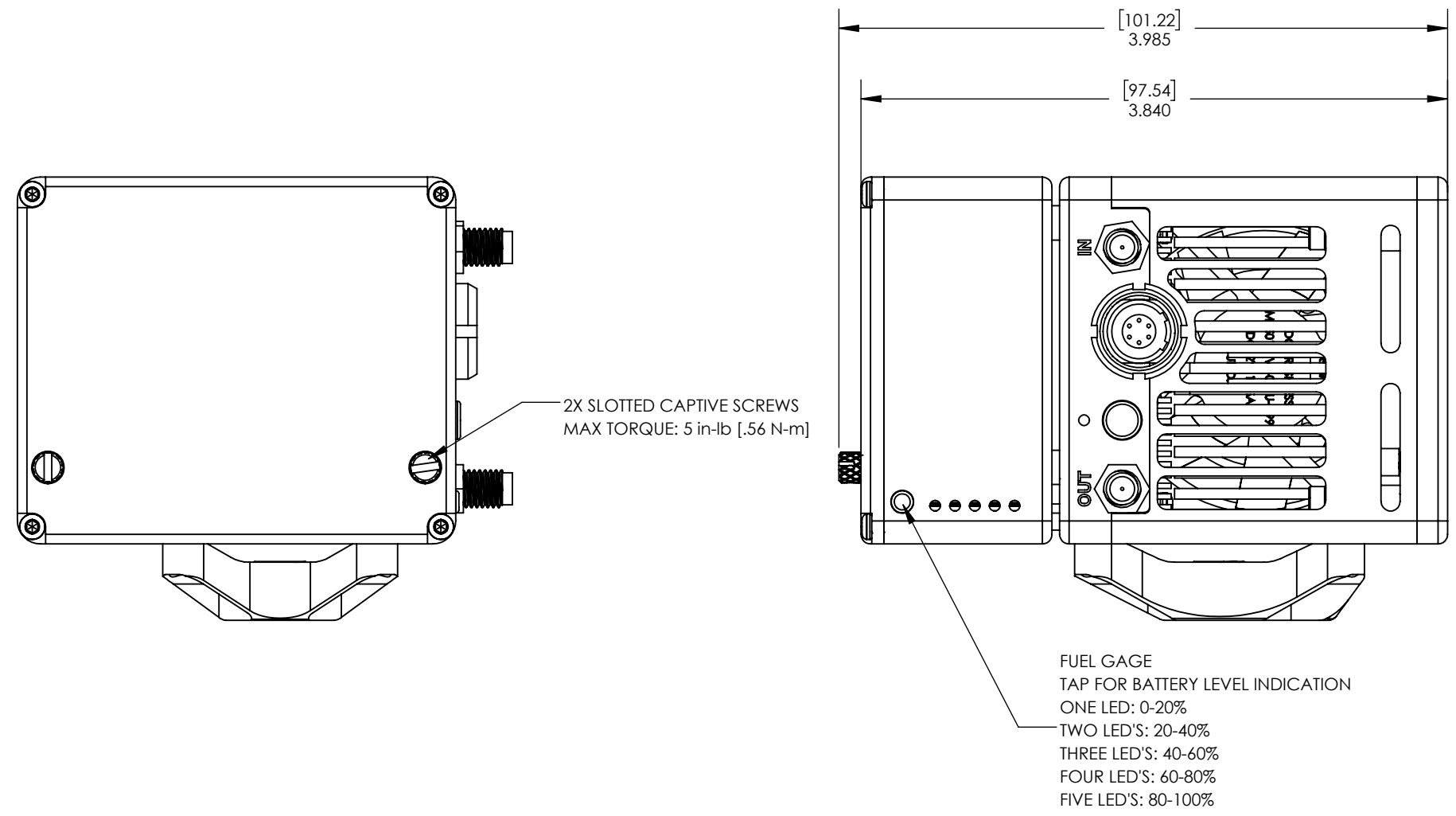

<b>PROPRIETARY AND CONFIDENTIAL</b> <small>THE INFORMATION CONTAINED IN THIS DRAWING IS THE SOLE PROPERTY OF INTEGRATED DESIGN TOOLS, INC. ANY REPRODUCTION IN PART OR AS A WHOLE WITHOUT THE WRITTEN PERMISSION OF INTEGRATED DESIGN TOOLS, INC. IS PROHIBITED.</small>	PROJECT NAME: C-160B mini	<b>INTEGRATED DESIGN TOOLS, INC</b> <small>1 WEST MOUNTAIN STREET SUITE 3                  PASADENA, CA 91103</small>		
	UNLESS OTHERWISE SPECIFIED: DIMENSIONS ARE IN INCHES TOLERANCES ON: FRACTIONAL DECIMAL ANGULAR ± 1/16 X ± .03 ± 1° .XX ± .01 .XXX ± .005	TITLE: INTERFACE CONTROL DOCUMENT (ICD), C-160B mini		
	<b>DO NOT SCALE DRAWING</b>	SIZE: <b>B</b>	DWG. NO. 1452-0100	REV A
THIRD ANGLE PROJECTION 		SCALE: 1:1	DATE: 4/23/2018	SHEET 2 OF 2

8 7 6 5 4 3 2 1